

2026

WHAT'S NEW IN GIBBSCAM 2026

Next-Generation Engine Redefines Advanced 3D Machining

GibbsCAM 2026 sets a new benchmark as the go-to solution for high-end CNC programming with the all-new Advanced 3D Maching engine that unlocks dramatically faster calculations, optimal toolpaths, and exceptional surface quality.

GibbsCAM 2026 is brimming with ergonomic advances and tools for smarter ways of working, like GibbsCAM Viewer for team-wide collaboration, upgraded Variable-B Turning and multi-axis machining, advanced simulation, tool management and more.

A New Era for Advanced 3D Machining

Advanced 3D Machining Engine

At the heart of GibbsCAM 2026 lies a completely re-engineered Advanced 3D Machining engine. This new core delivers significant gains in toolpath generation speed, ensuring faster programming cycles and fewer iterations.

GibbsCAM users will be at ease with familiar GibbsCAM interface without training, while enjoying a major boost in performance. The engine generates smoother, more predictable toolpaths, which translates into superior surface finishes and minimizes secondary finishing operations.

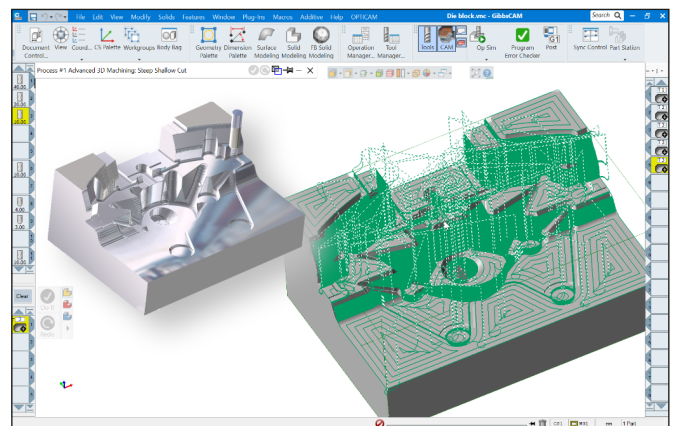

The new Advanced 3D Machining engine in GibbsCAM 2026 delivers faster toolpath generation and improved surface quality with the same familiar interface.

GibbsCAM Viewer — Access for the Entire Enterprise

The new GibbsCAM Viewer extends access to CAM data across the entire organization. This read-only tool allows operators, managers, and quality teams to inspect parts, verify geometry, analyze toolpaths, and generate reports—all without risking changes to toolpaths or NC code. By using the same familiar interface, the Viewer enhances collaboration, reduces communication errors, and keeps programming data secure. Machinists can visualize how parts will run and confidently expect high-quality results.

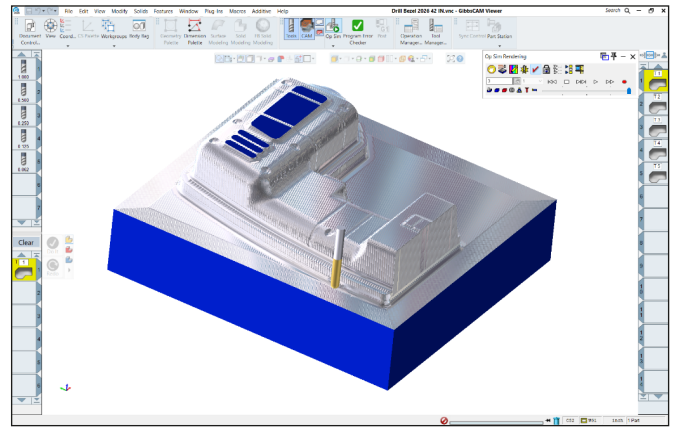

GibbsCAM Viewer enables company-wide visualization and analysis of CAM data while preserving a familiar user experience.

Advances in Turning and MTM Programming

Variable-B Turning — Interactive Intuitive workflow

GibbsCAM 2026 users can define tool angles directly along the cut path using control points, with smooth interpolation for precise control over complex operations. This makes complex turning operations easier to set up and more accurate, improving both flexibility and productivity.

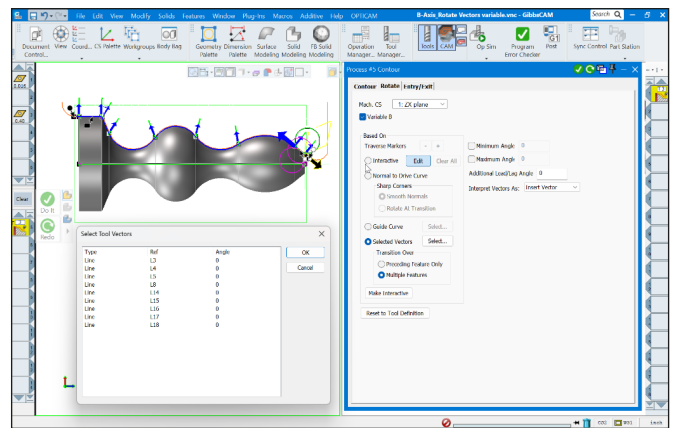

GibbsCAM 2026 improves Variable-B Turning with interactive control points, enabling smoother, more accurate machining and reduced setup effort.

Multi-Sided Turning — Smarter & More Efficient

For Multi-Sided Turning tools such as Sandvik Coromant's CoroTurn® Prime inserts, toolpath generation is now smarter and more efficient. The system calculates material engagement intelligently, maximizing insert geometry while maintaining safety. The result is improved material removal, consistent operation, and greater efficiency in advanced turning tasks.

Expanded Multi-Axis and 5-Axis Capabilities

Multi-Axis Machining — Advanced Tilting & Toolpaths

GibbsCAM 2026 expands its multi-axis machining capabilities with advanced tilting strategies and smarter toolpath orientation. The improved AutoTilt feature now supports bullnose tools, increasing versatility.

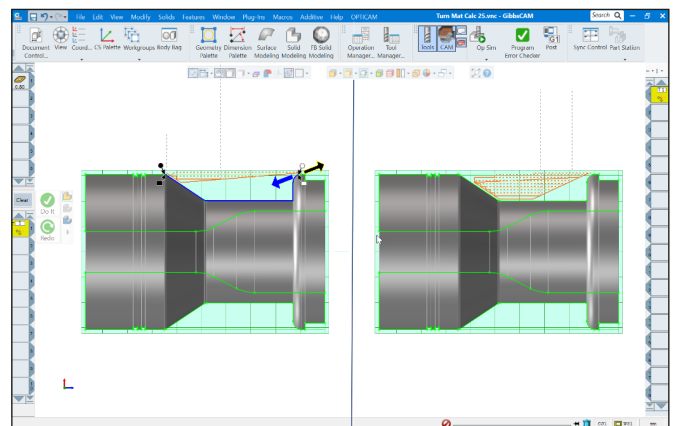

Two new strategies—Tilted into Plane and Tilt Tool in a User Defined Plane—give programmers precise control

GibbsCAM 2026 optimizes toolpaths for Multi-Sided Turning Tools such as Sandvik Coromant's CoroTurn® Prime inserts, for a more efficient material removal.

over tool axis orientation, aligning tilt with specific rotational axes for more stable machining. The enhanced automatic tilting kernel ensures consistent results across existing toolpaths and simplifies adoption of the latest features.

Multiblade Machining Improvements

The new Edge Finishing strategy delivers high-quality surface results while protecting delicate leading edges, and expanded tool support now includes flat end mills, bullnose mills, and taper tools. Users can customize feed rates for links, lead-ins, lead-outs, and edge extensions, reducing non-cutting time and optimizing cycle efficiency.

Additional upgrades include enhanced wall finishing, improved rotary machining finishing, and more effective deburring, giving operators greater control, speed, and precision across complex multi-axis operations.

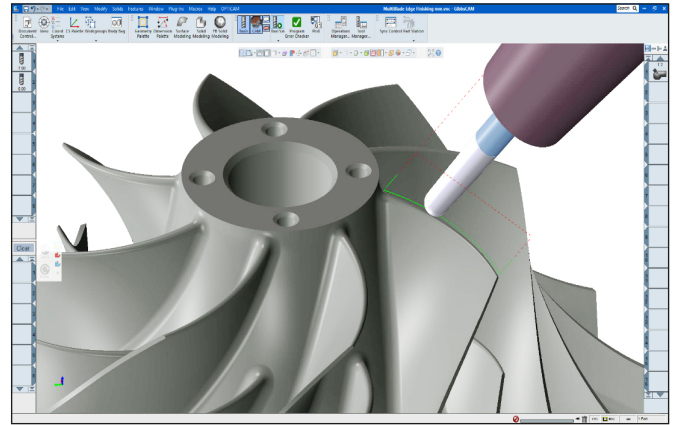

GibbsCAM 2026 enhances multiblade machining with advanced edge finishing, expanded tool options, and optimized feed control for greater efficiency.

Smarter Tool Management

Tool Usage Reporter

The new Tool Usage Reporter offers operation-based tracking of all tools used in a project. Accessible from the Tool dialog, this manager-style interface displays every operation linked to a selected tool.

Users can quickly identify, select, or remove tool-linked operations with intuitive row selection and workspace highlighting. This feature streamlines tool management and improves transparency.

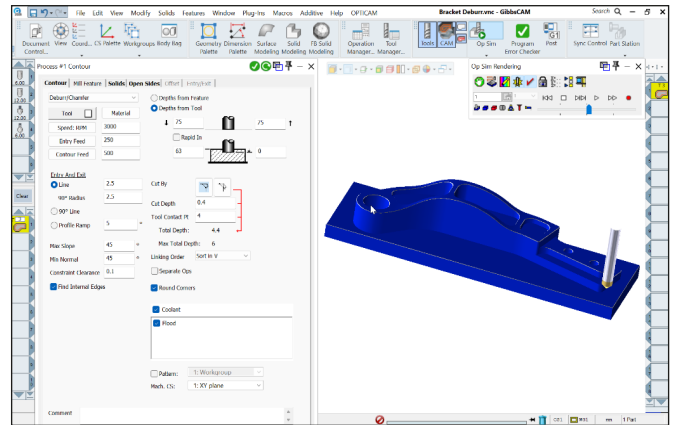

GibbsCAM 2026 simplifies and automates edge finishing with specific tool types, applying automatic deburring and chamfers efficiently.

Redesigned Tool List View

This spreadsheet-style view displays clear column labels for easier reviewing and editing tools. Both the standard and list views now support filtering by tool group, allowing users to isolate and manage specific sets of tools.

These enhancements improve workflow efficiency and simplify tool oversight, especially for complex projects.

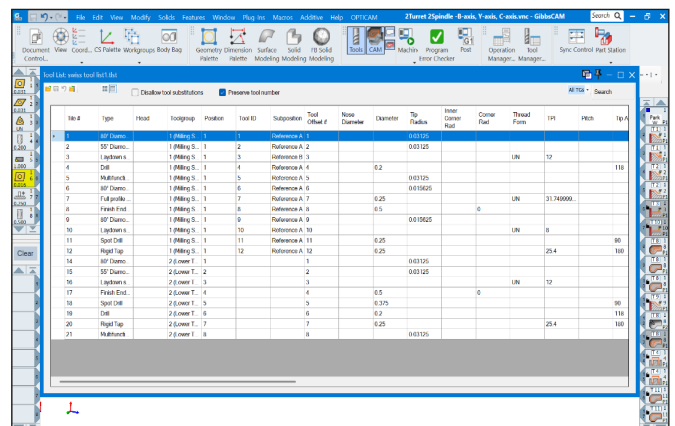

GibbsCAM 2026 streamlines tool management with a new usage reporter and enhanced list view, giving faster control and more transparent oversight in complex projects.

Easier Workflows & Simulation

Better Geometry Control

Users can now scale solids, sheets, and facet bodies with precision, rotate geometry out of plane without complex workarounds, and measure minimum and maximum distances for improved part inspection.

Easier Workflows

Stock definitions are more accurate with features like cylindrical Shrink Wrap, and Undo/Redo history navigation allows quick access to any point in the design process.

Accurate Simulation

Simulation playback now reflects actual machining time and includes metallic rendering options for enhanced visual clarity.

Stronger Portfolio with New Partner Solutions

VERICUT® Optimizer for GibbsCAM

Dynamically adjust feed rates to maintain ideal chip thickness. The result: 15-30% shorter cycle times, extended tool life, and consistent cutting quality—all without altering proven GibbsCAM toolpaths.

ToolManagerIQ™ for tools, holders & fixtures

Fully integrated with GibbsCAM through a robust SQL database and available as a standalone solution, it eliminates duplicated work, improves collaboration, and ensures reliable access to accurate tool data across the organization.

CloudNC CAM Assist — AI Automation for Programming

CloudNC CAM Assist offers cloud-based AI automation to generate complete 3-axis and 3+2 toolpaths directly from GibbsCAM session data, dramatically reducing programming time and helping companies address the shortage of experienced programmers.

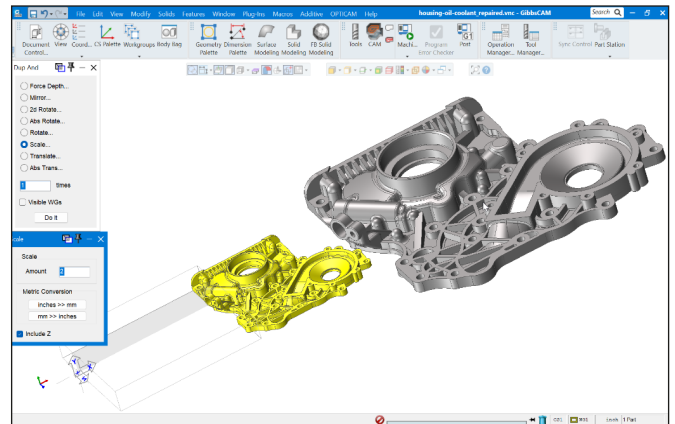

GibbsCAM 2026 enhances geometry control by enabling precise scaling of solids and sheets, and nonplanar rotation around any axis with live previews.

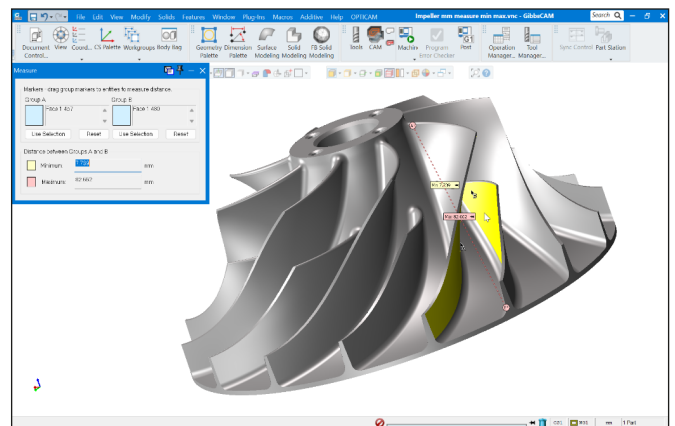

GibbsCAM 2026 enhances measurement functionality by showing min/max distances between 2D or 3D elements for more clarity during part inspection and setup verification.

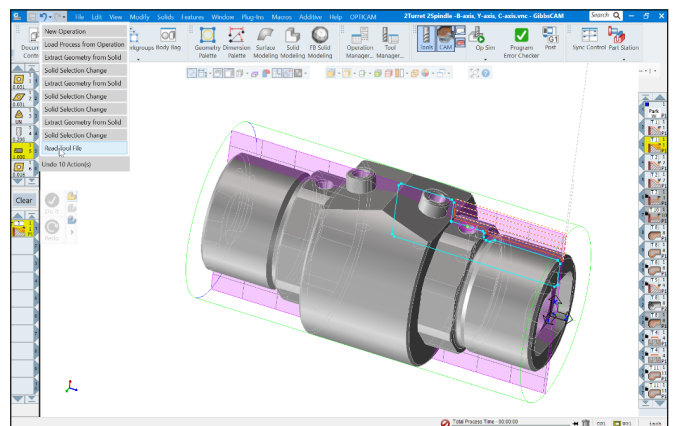

GibbsCAM 2026 streamlines Undo and Redo by letting users jump directly to any point in their action history.